

# Colamark

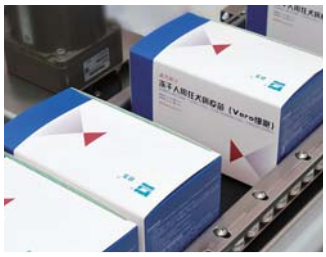

## Colamark A741 Top/Side Labeling System

A versatile system for flat surface labeling on the top or side of the object, the A741 comes with a full series of options and accessories, from separator, hold-down belt, clamping belt, inspection and rejection etc., to cater for a wide range of applications.



## Features

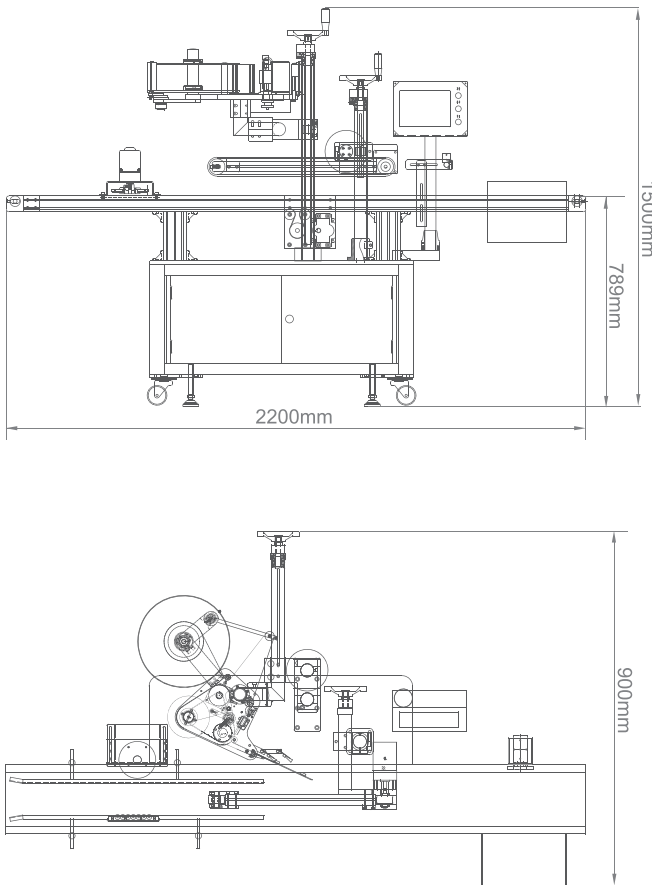

- Turn-around joint to allow change from top labeling mount to side labeling mode in seconds.
- Hold-down conveyor for side labeling and top labeling on light weight boxes.
- Simple single sided separation wheel for square shaped boxes or double sided separation wheel for thin and wide boxes.
- Various online coding/printing devices including hot stamping, CIJ, HP thermal inkjet, TTO, and thermal transfer print engine available for printing from a simple code to sophisticated database information and barcodes, with control or status monitor integration.
- Various inspection functions for missing codes, missing label, or unreadable barcodes with automatic rejection upon error.
- Touch control panel with user friendly operation menus.
- Memory of 50 sets of operation parameters.
- Servo motor driven labeling engine to ensure labeling accuracy and speed.
- World renowned brands of control and motion components complying with GMP standards to ensure long term durability and reliability.

Model	A741
Object dimensions	(L)150-170mm × (W)80-121mm × (H)15-30mm
Label dispensing speed	30m/min.
Labeling precision	±1.5 mm (excluding errors from materials)
Conveyor speed	40 m/min.
Options	Turn-around joint, separating wheel, hold-down belt, coding devices, vision inspection camera, barcode scanner, missing label inspection, missing code inspection, rejection device, extended conveyor,
Power consumption	220VAC±5% 50Hz 0.8kW
Machine denesions	(L)2,200mm × (W)900mm × (H)1,500 mm

(Custom engineered solutions are available to cater for customer's speccail needs.)

For continuous improvement on design and product innovations, all specification data are subject to change without prior notice

### Colamark (Guangzhou) Labeling Equipment Limited

19 Jin Xiu Road, GETDD, Guangzhou, China

Tel: +86 20 8221 6718 Fax: +86 20 8221 5799 PC:510730

**Colamark Technologies Limited** 820 Topsail Plaza,11 On Sum Street,Shatin, Hong Kong

Tel: +852 2634 8011 Fax: +852 8161 3311 Email: info@colamark.com Web: www.colamark.com

|HongKong | Guangzhou | Kunming Chengdu | Wuhan | Chongqing | Xian | Shanghai | Qingdao | Beijing | Shenyang | Harbin|